

Sur la table
KITCHEN ESSENTIALS

5 QT COMPACT AIR FRYER

OWNERS MANUAL



www.mcappliances.us
Model SE-1703-5



Scan here for bonus recipes and to watch how-to videos that will help you make the most of your air fryer, or go to www.mcappliances.us

BEFORE USE, PLEASE READ AND FOLLOW ALL IMPORTANT SAFEGUARDS, WARNINGS, CAUTIONS AND OPERATING INSTRUCTIONS.



Congratulations! You now own an 5 Qt Compact Air Fryer with easy digital preset controls for Air Fry, Bake, Roast, Broil, Chicken, Fries, Fish, and Meat to make every cooking experience a breeze in the kitchen.

Create chef quality meals without the extra calories and messy cleanups. It's the healthier choice on how to prepare your favorite crispy foods and delicious dishes for the entire family.

Please read the manual carefully before use and keep this manual for easy reference.

Enjoy!

Sur la table
KITCHEN ESSENTIALS

© 2023 Sur La Table. All Rights Reserved.

Products mentioned herein are for identification purposes only and may be registered trademarks of their respective companies. All brand names, trademarks or registered trademarks are the property of their respective owners.

This manual is only applicable to SE-1703-5. All the contents in this manual are for reference only during the user's use and maintenance. The pictures are for reference only. All the contents in the manual have been carefully checked. If there are any printing errors or misunderstandings in the contents, the company reserves the right to interpret.

TABLE OF CONTENTS

READ ALL INSTRUCTIONS PRIOR TO OPERATING	6
IMPORTANT SAFEGUARDS AND WARNINGS	6
WHAT'S IN THE BOX	12
GETTING TO KNOW YOUR AIR FRYER	13
AIR FRYER FEATURES	14
AIR FRYER ASSEMBLY	15
BEFORE THE FIRST USE	16
PRE-PROGRAMMED COOKING SELECTIONS	17
QUICK START GUIDE	18
AIR FRYING TECHNIQUES	22
COOKING TIPS	23
CLEANING AND MAINTENANCE	26
STORING INSTRUCTIONS	26
TROUBLESHOOTING	27
ENVIRONMENT FRIENDLY DISPOSAL	28
WARRANTY	28



READ ALL INSTRUCTIONS PRIOR TO OPERATING

- This manual is a comprehensive step-by-step user instruction guide for the **5 Qt Compact Air Fryer** and components.
- Make sure to read, understand and follow all these instructions.
- To address any questions relating to ordering parts, operating, assembly, troubleshooting, maintenance, service or anything else; contact **Customer Service Support Team at 1-877-246-0990 or email us at appliancesupport@monchateau.us**
- **Keep this manual in a location where it may be used for ongoing reference.**

IMPORTANT SAFEGUARDS AND WARNINGS

- Unplug the **Compact Air Fryer** from outlet when **NOT in use**, before putting on or taking off parts, and before cleaning or removing contents from air fryer. Make sure air fryer has cooled down first for about 30 minutes. Before disconnecting plug, press ON/OFF control to turn off the air fryer, then remove power plug from power outlet by grasping the plug, not the cord.
- **WARNING: Always keep a fire extinguisher nearby when cooking.**
- **Never leave the Compact Air Fryer unattended when in use.**
- **Never** put hands directly on the surrounding surfaces as they may be hot and can cause serious injuries or burns.
- **Always** use oven mitts to grab basket handles, crisper baking tray, and remove food from air fryer since hot surfaces can cause serious injuries or burns. **Never** touch the hot food.
- Always grab the basket by its handles with oven mitts.
- Always allow air fryer or oven to cool before cleaning or handling, putting on or taking off parts.
- Always make sure the air fryer basket is fully inserted and locked in place before operating.
- The **Compact Air Fryer** is a household appliance designed for indoor use **ONLY** and normal temperature conditions.
- Do **NOT** use the **Compact Air Fryer** outdoors, it could cause serious injuries if it gets wet.
- Make sure the voltage of the power source is the same as specified on the rating plate of the **Compact Air Fryer**. The use of an incorrect power source connection voids the warranty and can cause a fire, death, or serious injuries.
- Do **NOT** let power cord hang over the edge of counter, or touch hot surfaces.
- Do **NOT** operate the **Compact Air Fryer** with a damaged cord or plug or after the appliance

malfunctions or has been damaged in any manner. Return the appliance to the nearest authorized service facility for examination, repair, or adjustment.

- Close supervision is necessary when any appliance is used near children.
- The use of attachments not recommended or sold by manufacturer may cause fire, electric shock, death, or serious injuries.
- **Children cannot use the Compact Air Fryer. Keep this appliance and its cord out of the reach of children and pets.**
- When removing the food basket from the air fryer, make sure the appliance is off to avoid serious injuries or burns.
- **Make sure you always have a First-Aid Kit nearby.**
- **Always operate the Compact Air Fryer with the basket secured in place.**
- **When using the crisper baking tray, make sure it is properly inserted into the air fryer basket before cooking. Place food on top of crisper baking tray.**
- **To check on food, use oven mitts to grab the basket handle and partially pull open the basket. If food is cooked, turn off the air fryer. If not push basket back in place and continue cooking.**
- **WARNING: The Compact Air Fryer will NOT function unless the basket is fully inserted and locked in place.**
- **WARNING: The basket and crisper baking tray will be extremely HOT after every use. Make sure you use oven mitts to protect your hands.**
- Do **NOT** use the **Compact Air Fryer** for other than its intended use.
- Always unplug the **Compact Air Fryer** from the power outlet if it is left unattended or not being used.
- To protect against electrical hazards, and permanent damage, **NEVER** put the **Compact Air Fryer** in water or other liquids.
- Avoid coming into contact with hot parts to avoid serious injuries.
- **When in use handle the Compact Air Fryer with care to avoid serious burns and injuries.**
- Do **NOT** operate the **Compact Air Fryer** in an appliance garage. When storing this air fryer in an appliance garage, always unplug the unit from electrical outlet. Not doing so could create a risk of fire, especially if the oven touches the walls of the garage or the door touches the unit as it closes.
- **The Compact Air Fryer will be hot after each use until it cools down — do not touch with bare hands since this could cause serious injuries and burns.**
- The **Compact Air Fryer** should **NOT** be used in staff kitchen areas, shops, offices, other working environments, farm houses, in hotels or motels, bed and breakfast rentals, or any other types of residential environments.
- Do **NOT** place the **Compact Air Fryer** next to or near a fryer, countertop oven or any other appliance that might get hot.

IMPORTANT SAFEGUARDS AND WARNINGS (CONT.)

- Protect the **Compact Air Fryer** from direct sunlight, prolonged water splashes and humidity.
- The **Compact Air Fryer** should **NOT** be used by or near children or individuals with certain disabilities.
- The **Compact Air Fryer** must **NOT** be used, cleaned, or maintained by children.
- The **Compact Air Fryer** is **NOT** a toy and can **NOT** be used by children to play.
- The brand owners, manufacturer, partners, affiliates, or anyone working with the production of the **Compact Air Fryer** accepts no responsibility and warranty will be voided if; the **Compact Air Fryer** is commercially used, inappropriately handled or used; any damage from misuse, faulty operation, non-professional repairs or failure to comply with the instructions in this manual and the proper use of this appliance.
- **WARNING: Avoid risk of fatal electrical shock and fire. Electricity and water together are dangerous and can lead to fatal electrical shocks, death, or serious injuries.**
- In case of an emergency, immediately remove the power plug from the power outlet. **ONLY** plug the **Compact Air Fryer** into suitable, easily accessible and grounded outlet connections.
- Keep the power cord away from heat, dampness, and moisture of any kind.
- If the power cord is damaged, **DO NOT USE** the **Compact Air Fryer** until the power cord is replaced by the manufacturer, its service agent, or a similar qualified and certified technician in order to avoid all risks included but not limited to fire, death, and personal serious injuries.
- To avoid hazardous damage, never place the **Compact Air Fryer** on or beside hot surfaces such as radiators, stoves, ovens, gas burners, open flames or any surfaces that are not sturdy.
- Do **NOT** touch any hot surfaces or steam to avoid serious injuries. Use handles and oven mitts.
- Always place the **Compact Air Fryer** on a horizontal, stable, sturdy and even surface that is heat resistant and away from walls and other objects by at least 4 inches.
- Never place the **Compact Air Fryer** underneath a cabinet or shelf or inside a cabinet. Air must always be allowed to circulate around the air fryer.
- Disconnect the power cord by pulling out the plug, do **NOT** pull on the cord itself to avoid damages.
- **Never** touch the cord with wet hands.
- **Never** put the **Compact Air Fryer** or any part of it in the dishwasher.
- **ONLY the crisper baking tray is dishwasher safe.**

- **NEVER** put aluminum foil in the **Compact Air Fryer**.
- **CAUTION HOT SURFACES: This Compact Air Fryer generates heat and may release steam during use. Proper precautions must be taken to prevent the risk of burns, fires or other injuries to persons or damage to property.**
- **CAUTION: The Compact Air Fryer retains heat for some time after turning OFF.**
- Do **NOT** open the factory set screws on the **Compact Air Fryer** to look inside the motor because there is dangerous voltage inside, and this can cause fire, death, or serious injuries. Do **NOT** dismantle or open the compact air fryer in any way since this will void the warranty. Do **NOT** put anything into any openings; doing so may cause fire, electric shock, death, or serious injuries.
- The use of accessory attachments not recommended by the manufacturer will void warranty and may result in fire, electric shock, death, or serious injuries.

WARNING: Avoid possible harm when operating the Compact Air Fryer.

- Do **NOT** use the **Compact Air Fryer** if it is damaged, has been dropped or **NOT** operating properly. Immediately remove the power plug from the power outlet.
- Do **NOT** use any strong cleaning agents or solvent cleaners. Use a damp cloth and mild cleaning agents to clean the surface and removable parts for the **Compact Air Fryer**. Make sure surfaces are dry.
- Do **NOT** use steam or a pressure cleaner to clean the **Compact Air Fryer**, this may damage the appliance to the point of creating a life-threatening hazard, electrical shock, death, or serious injuries.
- To clean the **Compact Air Fryer**, use only clean cleaning tools.
- When unpacking the **Compact Air Fryer**, remove any plastic film and dispose of it.
- Do **NOT** let children play with the packing materials, plastic film, or box for the **Compact Air Fryer**; since these can be a choking hazard, and cause death or serious injuries.
- If you are sensitive to heat or are unable to feel hot surfaces, you **MUST** wear heat protective gloves to prevent serious injuries from hot surfaces.
- Do **NOT** clean the **Compact Air Fryer** with cleansers, steel wool pads, or other abrasive materials.
- **WARNING: TO REDUCE THE RISK OF FIRE OR ELECTRIC SHOCK, DO NOT REMOVE THE BASE PANEL. NO USER-SERVICEABLE PARTS ARE INSIDE. REPAIRS SHOULD BE DONE ONLY BY AUTHORIZED PERSONNEL.**
- Do **NOT** place cloth beneath the **Compact Air Fryer** or otherwise restrict airflow.
- To avoid burns, use extreme caution when removing Air Fryer Basket or accessories disposing of hot grease.
- Do **NOT** place any of the following materials in the Compact Air Fryer: paper, cardboard, plastic, foil wrap and similar products. **ONLY** place food inside the basket or on top of the crisper baking tray.
- **WARNING: The Compact Air Fryer should not be used to boil water.**

IMPORTANT SAFEGUARDS AND WARNINGS (CONT.)

- **WARNING:** The **Compact Air Fryer** should not be used to deep fry foods.
- Oversize foods, metal foil packages and utensils must **NOT** be inserted in the **Compact Air Fryer**, as they may cause a fire or electric shock.
- A fire may occur if the **Compact Air Fryer** is covered or touching flammable materials such as curtains, draperies, or walls, when in operation. Do **NOT** store or place any items on top of the appliance when in operation.
- Do **NOT** clean with metal scouring pads. Pieces can break off the pad and touch electrical parts, involving a risk of electric shock or fire.
- Use recommended temperature settings for all cooking, baking, roasting and air frying.
- **WARNING:** Under or over filling the air fryer basket may damage the air fryer and result in serious personal injuries.
- Do **NOT** move the **HOT Compact Air Fryer** while in use or while it contains hot food.
- **Never place a cooking container full of grease or hot liquids inside the Compact Air Fryer.**
- **Clean air fryer basket, crisper baking tray after each use.**

Electrical Power

- **If the electrical circuit is overloaded with other appliances, your 5 Qt Compact Air Fryer may not operate properly. It should be operated on a separate electrical circuit from other appliances.**

WARNING: RISK OF FIRE OR ELECTRIC SHOCK



**WARNING: TO REDUCE THE RISK OF FIRE OR ELECTRIC SHOCK,
DO NOT REMOVE COVER (OR BACK)**

NO USER-SERVICEABLE PARTS INSIDE

REPAIR SHOULD BE DONE BY AUTHORIZED SERVICE PERSONNEL ONLY

SHORT CORD INSTRUCTIONS

- To reduce the risk of electric shock, this power cord is intended to fit into a polarized outlet **ONLY** one way. If the power cord plug does **NOT** fit fully into the power outlet, reverse the power cord plug and insert into the power outlet. If it still does not fit, contact a qualified electrician or customer service.
- Do **NOT** attempt to modify the power cord plug in any way.

SAVE THESE INSTRUCTIONS HOUSEHOLD USE ONLY

WHAT'S IN THE BOX

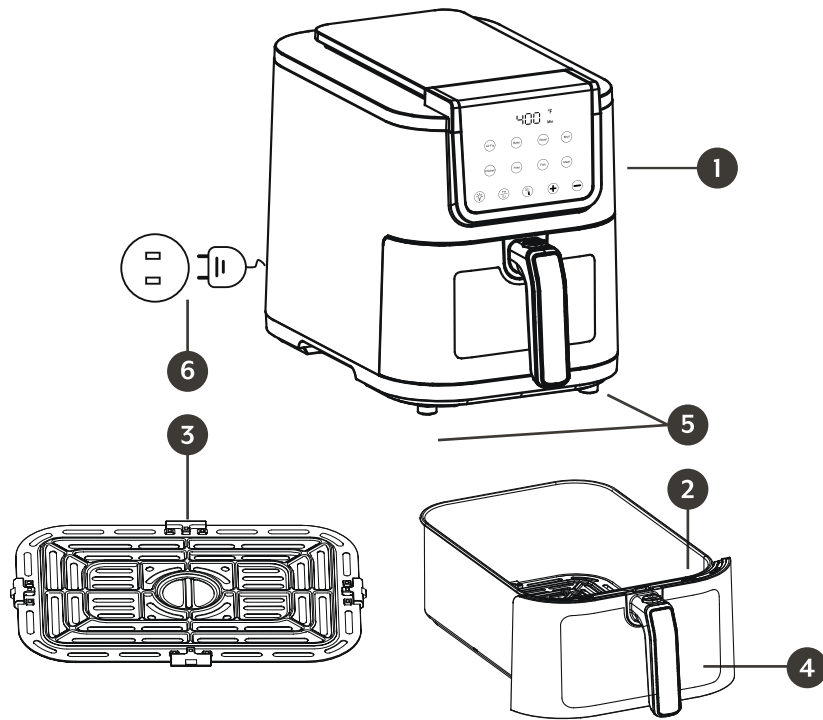

1 DIGITAL TOUCHSCREEN CONTROLS

2 AIR FRYER BASKET

- 5 Quarts
- Removable Basket with Handle
- Must always be cleaned after each use

3 CRISPER BAKING TRAY

- Place food on removable Tray
- Must always be cleaned after each use
- Dishwasher Safe

4 AIR FRYER BASKET HANDLE

- Used to remove and insert Basket into Air Fryer
- Always grab with oven mitts

5 NON-SKID FEET

6 POWER CORD WITH POLARIZED PLUG

GETTING TO KNOW YOUR AIR FRYER

Digital Touchscreen Controls

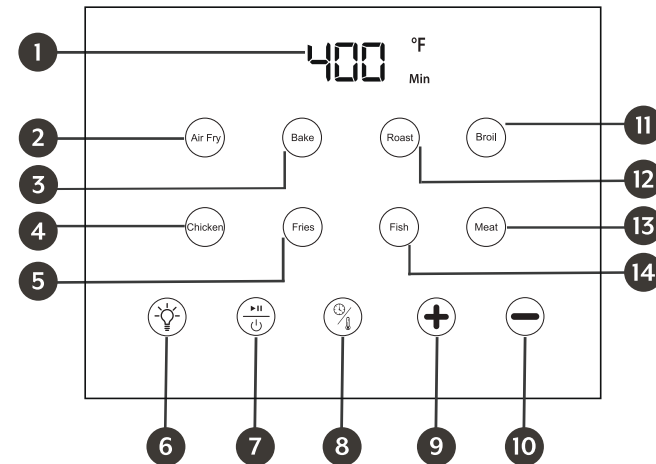

1 TEMPERATURE THEN TIME DISPLAY

2 AIR FRY

3 BAKE

4 CHICKEN

5 FRIES

6 LIGHT CONTROL

7 ON/ OFF OR PAUSE CONTROL

8 TIME/ TEMPERATURE CONTROL

9 INCREASE TIME/ TEMPERATURE CONTROL (+)

10 DECREASE TIME/ TEMPERATURE CONTROL (-)

11 BROIL

12 ROAST

13 MEAT

14 FISH

INCREASE OR DECREASE TIME / TEMPERATURE CONTROL (+ OR -)

Press + or – on the control panel to increase or reduce TEMPERATURE / TIME.

TEMPERATURE / TIME CONTROL

Press this button to toggle between TIME and TEMPERATURE.

ON/OFF OR PAUSE CONTROL

Once programming is complete, press the ON/OFF Control to turn ON the Air Fryer with a short beep sound.

The ON/OFF or Pause Control lights up, other LED icons are always on.

The display panel displays the temperature first then the time in 5 second intervals.

Press the Pause Control to pause the cooking process, press it again and it will restart the cooking process.

Long press of the ON/OFF Control for 2 seconds and the Air Fryer will turn OFF.

NOTE: According to the SHAKE program settings, the food has cooked 2/3 of the time, the Air Fryer will beep, the display will show a flashing SHK indicating that you are being reminded to shake or flip your food for an even air frying on all sides of the food.

AIR FRYER FEATURES



- Digital Touchscreen Controls
- Digital Temperature (°F) and Time Display
- Removable Air Fryer Basket with Handle
 - 5 Quarts
- Removable Crisper Baking Tray
- Non-Skid Feet
- Preset Menu Controls
 - Air Fry, Bake, Roast, Broil, Chicken,
 - Fries, Fish, Meat
- Temperature Controls
- Time Controls
- ON/OFF or Pause Control
- Inner Light
- Window

AIR FRYER ASSEMBLY

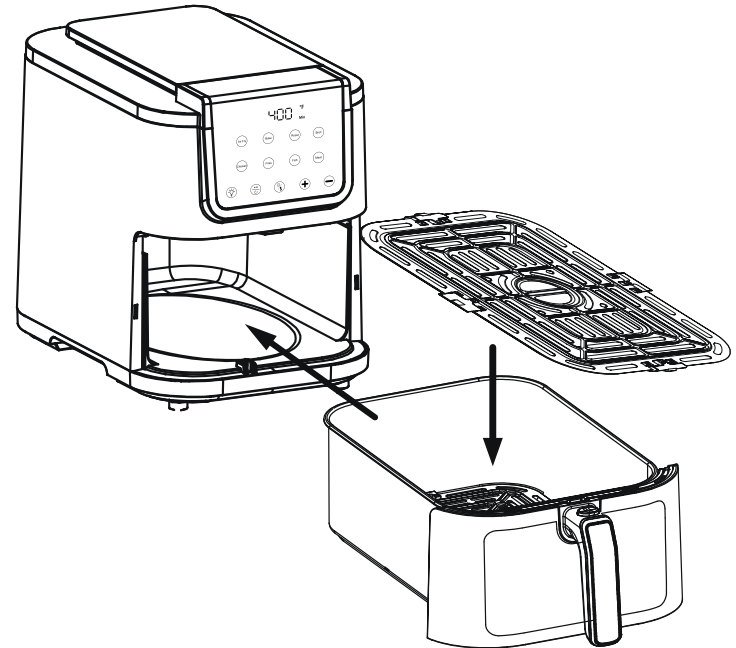

BEFORE THE FIRST USE

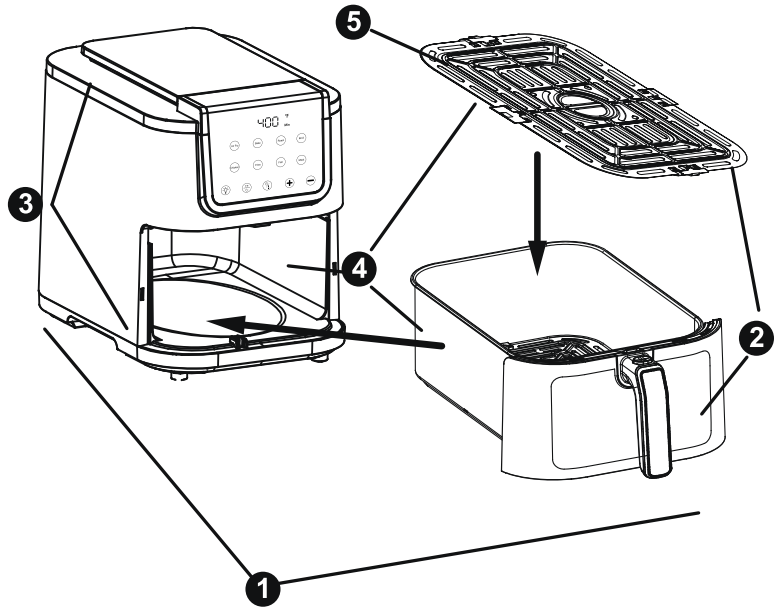

- 1 Remove all accessories and fittings from the air fryer or from the box.
- 2 Clean the inside of the fryer with warm water and wipe the inside of the air fryer with a soft damp cloth and wait until it is completely dry before using.
- 3 There should be enough space around the air fryer to ensure that the surface of the air fryer is at least 4 inches away from other items and that nothing is placed on top of the air fryer.
- 4 Before operating the air fryer for the first time, the temperature should be set to the maximum and run 10-15 minutes to remove any remnant oil left on the surface of the air fryer. It is normal to have some light smoke coming out when first used.
- 5 Use Crisper Baking Tray Handles to remove and insert Tray into Basket.

NOTE: During first use (preheat 10-15 minutes) the 5 QT Compact Air Fryer may emit a slight odor or smoke. This is normal and will not affect the flavor of the food. Do NOT place anything on top of the Air Fryer or around it and move it away from cabinets and walls.

PRE-PROGRAMMED COOKING SELECTIONS

MENU	DEFAULT TEMP (°F)	TEMP RANGE (°F)	DEFAULT TIME MINUTES (Min)	TIME RANGE MINUTES	FOOD SHAKE
Air Fry	400°F	150~400°F	20	01-60min	2/3
Bake	300°F	150~400°F	20	01-60min	NO
Roast	380°F	150~400°F	15	01-60min	2/3
Broil	400°F	150~400°F	6	01-60min	2/3
Chicken	400°F	150~400°F	25	01-60min	2/3
Fries	400°F	150~400°F	20	01-60min	2/3
Fish	320°F	150~400°F	15	01-60min	2/3
Meat	380°F	150~400°F	15	01-60min	2/3

IMPORTANT: The above pre-programmed selections are for reference only, the specific cooking time and temperature needs to be adjusted according to the actual size and quantity of food. Follow recipe suggestions and personal preferences.

QUICK START GUIDE

Operating Instructions

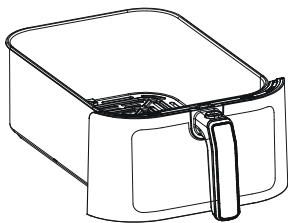

IMPORTANT: Maximum Food Capacity for Air Fryer Basket is 5 Quarts of food.

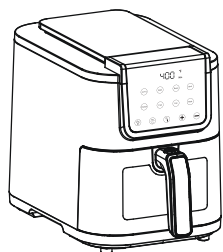

1. Place the Air Fryer on a flat, stable, heat resistant surface and close to an electrical outlet.

WARNING: Do NOT place Air Fryer underneath cabinets. Place the Air Fryer away from the wall. Do NOT place anything on top of it.

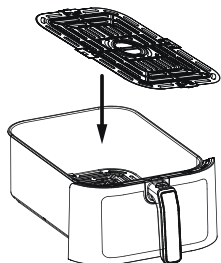

2. Press the Basket release Button, pull the Basket outward by the handle and place Basket on a flat heat resistant surface. Insert clean Crisper Baking Tray into Air Fryer Basket.

NOTE: If not using the Air Fryer for the first time, and skip steps 5 and 6.

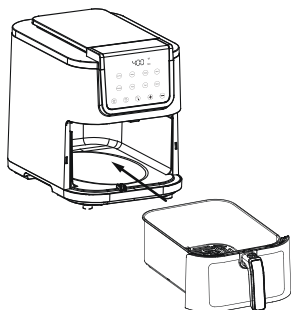

3. Insert Air Fryer Basket into Air Fryer and lock into place.

Start Cooking

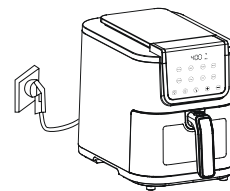

4. Plug the Air Fryer cord into an electrical outlet. An audible tone will sound, the Control Panel will illuminate. The ON/OFF Control will light up white.

5. Press the ON/OFF Control to turn the Air Fryer ON and run for 10-15 minutes.

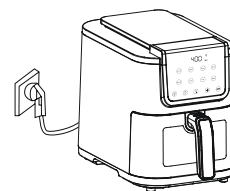

NOTE: During first use (preheat 10-15 minutes) the 5 Qt Compact Air Fryer may emit a slight odor or smoke. This is normal and will not affect the flavor of the food.

6. When done, press the Basket release Button, pull the Basket outward by the handle and place Basket on a flat heat resistant surface.

WARNING: Use Oven Mitts to grab Basket Handle. The Basket will be HOT.

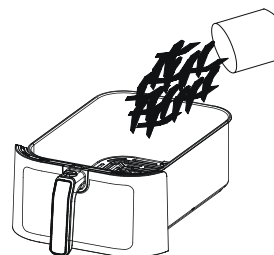

7. Place food into Air Fryer Basket.

WARNING: Do NOT Overfill. To ensure proper cooking and air circulation, NEVER fill the Air Fryer Basket more than 2/3 full.

NOTE: When air frying fresh vegetables, it is NOT recommended to add more than 2 to 3 cups of food to the Air Fryer Basket.

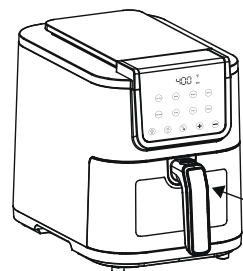

8. Insert Air Fryer Basket into Air Fryer and lock into place.

QUICK START GUIDE (CONT.)

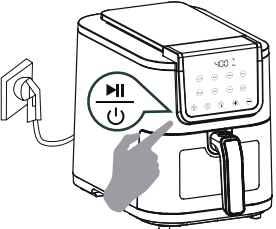
Start Cooking	
	<p>9. Press the ON/OFF button, the whole panel will light up white, and the display will show “---” first. After pressing the menu button, the display will show the temperature and time.</p>
	<p>10. Press desired Menu control for the food you are cooking or adjust it to the right time and temperature according to your preference.</p> <p>11. Press lightbulb button to turn on the light ON/OFF. The light will stay on for a minute then turn off by default.</p> <p>NOTE:</p> <ul style="list-style-type: none"> • Press the Pause Control to pause the cooking process, press it again and it will restart the cooking process. • Long press of the ON/OFF Control for 2 seconds and the Air Fryer will turn OFF.

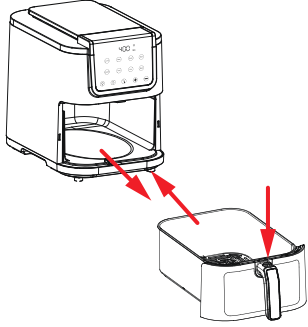
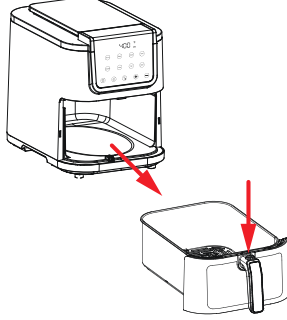
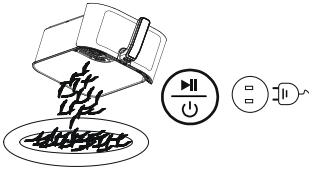
Cooking	
	<p>12. The Shake reminder will sound during the cooking process, press release button on Basket Handle to remove basket and shake food and then insert basket back into the Air Fryer and continue cooking.</p> <p>WARNING: Use an Oven Mitts to grab Basket Handle. The basket will be HOT.</p> <p>NOTE: You can press the Pause Control at any time during the cooking process.</p>
	<p>13. When the food is done cooking, press the release button on the Basket Handle to remove the basket from the Air Fryer.</p> <p>WARNING: Use an Oven Mitts to grab Basket Handle. The basket will be HOT.</p>
	<p>14. Place the Basket on a heat-resistant surface to remove the food or tip the basket over a serving dish.</p> <p>WARNING: DO NOT get burned. Avoid steam, hot basket, and hot food.</p> <p>15. Press the ON/OFF Control to turn the Air Fryer OFF and unplug it from the electrical outlet.</p>

AIR FRYING TECHNIQUES

NOTE: Consult the Pre-Programmed Cooking Selections or follow the food package directions for suggested TIME and TEMPERATURE.

- Always pat food dry before cooking to promote browning and avoid excess smoke.
- To assure even cooking and browning, always open the Air Fryer Basket halfway through the cook time and check, turn or shake foods in the Basket.
- Some recipes may call to brush or spray oil halfway through the cooking process and adjust TIME and TEMPERATURE if needed.
- **WARNING:** Extreme caution must be used when handling any hot food, Basket, or Crisper Baking Tray. Avoid escaping steam from the Air Fryer Basket and the food.
- **CAUTION:** Always use oven mitts when handling the HOT Air Fryer Basket.
- **CAUTION:** Hot oil can collect at the base of the Basket. Use caution when removing cooked foods.
- To avoid excess smoke when cooking naturally high fat foods, such as bacon, chicken wings or sausages, it may be necessary to empty fat from the Air Fryer between batches of cooking food.
- To ensure crispiness, make sure the skin or exterior food surface is dry. Air Fry small batches of freshly breaded foods.
- Create more surface area by cutting food into smaller pieces.
- Press breading onto food to help it adhere.
- Refrigerate breaded foods for at least 30 minutes before Air Frying.
- To improve crispiness, cover poultry skin or exterior surface lightly with corn starch and spray with oil.
- Arrange breaded food in Air Fryer Basket so that the food is not touching to allow air to flow through all surfaces. Spray oil works best if distributed evenly and less oil is needed. Canola, olive, avocado, coconut, grapeseed, peanut, or vegetable oil work best.

COOKING TIPS

Air Frying Pre-Packed Frozen Foods

- As a rule, depending on the food and amount to be cooked, suggested cooking times may have to be reduced slightly.
- Always check food halfway through cooking time to determine final cook time and temperature.
- Always check cooking progress after time has expired.

Roast

- **IMPORTANT: Consult the USDA Cooking Guidelines in this manual before cooking. Always test meats using an accurate cooking thermometer.**
- Use a meat thermometer inserted into the center of the meat to determine desired doneness.
- Cook meats to 5 to 10 degrees below desired doneness (internal temperature). Allow meat to stand 15 to 20 minutes before serving. The food temperature will continue to rise while the food is resting.
- Roast large, tender cuts of meat and poultry. Seasoning prior to cooking adds to the flavor and aroma during cooking.
- A layer of fat on the top of the roast promotes better browning and provides natural basting.
- To speed up the browning process, brush lean cuts of meat, chicken and fish with oil, margarine, or melted butter.
- Place meat (fat side up) and turn over half-way through roast time.
- **IMPORTANT:** Turn and check food halfway through roast time.

COOKING TIPS (CONT.)

Broil

- Use BROIL to melt cheese or to brown crumb toppings.
- Typically, BROIL is used for thinner, tender cuts of meats, or marinated meats, chops, poultry or fish, fruits, and vegetables.
- Dry marinated meats and fish before broiling. Always pat meat dry to reduce smoke and promote brownness during broiling.
- To speed up browning and add flavor, brush lean cuts of meat, chicken and fish with oil or melted butter.
- Trim excess fat from meat and score edges to prevent curling.
- Thaw frozen meats and fish before broiling.
- Broil time is determined by the desired doneness. Always use a meat thermometer.

Bake

- When using BAKE, you may need to lower the bake recipe temperature by 50°F to a minimum of 300°F.
- Check package directions to determine if the container is suitable for use in an Air Fryer.

Fruit and Vegetables

- Wash all fruit skins well.
- Slice fruit into 1/4 inch thick slices and arrange with space between each slice to ensure even drying.
- Rotate foods halfway through DEHYDRATE time for even drying.

USDA COOKING GUIDELINES

- The USDA recommends that meats such as beef and lamb, etc. should be cooked to an internal temperature of 145°F (63°C).
- Pork should be cooked to an internal temperature of 160°F (71°C).
- Poultry products should be cooked to an internal temperature of 165°F (74°C) to make sure any harmful bacteria have been killed.
- When reheating meat and poultry products, they should also be cooked to an internal temperature of 165°F (74°C).

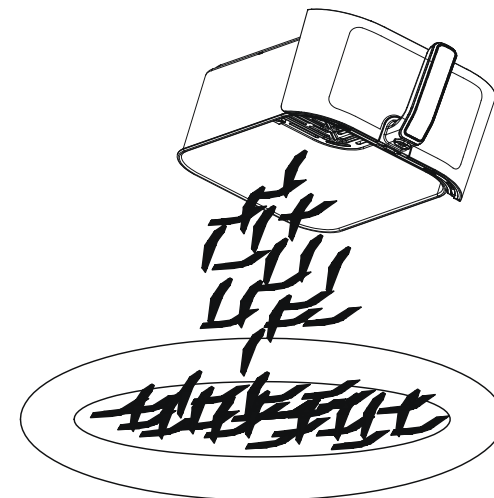

CLEANING AND MAINTENANCE

- This **Air Fryer** requires very little maintenance. It contains no user-serviceable parts. Any servicing requiring disassembly other than cleaning must be performed by a qualified appliance repair technician.
- **WARNING:** Allow the Air Fryer to cool fully before cleaning.
- Unplug the **Air Fryer**. **IMPORTANT: Clean after every use.**
- Remove the Air Fryer Basket from the Air Fryer.
- Make sure Air Fryer Basket, and Crisper Baking Tray have cooled completely before cleaning.
- Wash Air Fryer Basket, and Crisper Baking Tray in warm soapy water and rinse well. Hand dry with a soft cloth.
- Do not use metal Kitchen utensils or abrasive cleaners or cleaning products as these may damage the non-stick coating.
- Only the Crisper Baking Tray is dishwasher safe.
- Wipe the **Air Fryer** with a soft, non-abrasive damp cloth to clean it. Then use a dry soft cloth to dry all surfaces.
- **WARNING: Never place the Air Fryer in water or other liquids.**

STORING INSTRUCTIONS

- Make sure the Air Fryer is unplugged and all parts are clean and dry before storing.
- Never store the Air Fryer while it is hot or wet.
- Insert the clean Crisper Baking Tray inside the Air Fryer.
- Store Air Fryer in its box or in a clean, dry place.

TROUBLESHOOTING

Issues	Reasons	Solutions
Display panel does not light up	Power Failure	Check and maintain power supply equipment
	Unit is not plugged in correctly / power outlet does not have power	
	Power supply voltage does not match the rated voltage of the product	
	Circuit Board Failure	Send to designated maintenance department for repair
Food is undercooked / burnt	Wrong bake temperature or time selected	Divide ingredients into fryer in small batches. Small batches allow for more even heating. Adjust the temperature to the desired temperature and adjust the time to the desired baking time
	Too many ingredients in the basket	
	Baking temperature is too low	
	Baking time is too short	
Smoke comes out at first use	Anti-rust oil left on the heat pipe of the air fryer	Turn the temperature up to maximum and heat the air fryer for 10-15 minutes to remove the anti-rust oil from the heat pipe
Appearing Odor	Left over food on the crisper plate	Clean the Crisper baking tray and basket
No response to display panel	There are oil or water stains on the screen.	Please wipe your hands and display panel with a cloth
	There are oil or water stains on the hands.	

NOTE: If Air Fryer still does not work properly, contact Customer Service Support Team at (877) 246-0990 or email us at appliancesupport@monchateau.us



Environment Friendly Disposal

You can help protect the environment! Please remember to respect the local regulations. Take non-working electrical equipment to an appropriate waste disposal center or contact the retailer where the product was purchased. They can take this product for environmentally safe recycling.

1 YEAR LIMITED WARRANTY

Customer Service:

TEL: (877) 246-0990

www.surlatable.us

appliancesupport@monchateau.us



LIMITED 1 YEAR WARRANTY

The manufacturer warrants, subject to the conditions stated below, this product will be free from mechanical defects for a period of ONE (1) year from the date of purchase. The manufacturer, at its discretion, will repair or replace the product found to be defective during the warranty period. Should this product become defective by reason of improper workmanship or material defect during the specified warranty period, the manufacturer will repair or replace the same effecting all necessary parts replacements for a period of ONE (1) year from the date of purchase.

This warranty is available to consumers only. You are a consumer if you own a Sur La Table product that was purchased at retail for personal, family or household use. Except as otherwise required under applicable law, this warranty is not available to retailers or other commercial purchasers or owners.

CONDITIONS:

This warranty is valid for the original USA, Canada, or Mexico retail purchaser from the date of initial retail purchase and is not transferable. Keep the original sales receipt. Proof of purchase is required to obtain warranty service or replacement. Dealers, service centers, or retail stores do not have the right to alter, modify or in any way, change the terms and conditions of this warranty. Warranty registration is recommended, but not required. Save your proof of purchase receipt.

ABOUT YOUR PRODUCT WARRANTY:

The warranty is void if the manufacturing date or the serial number on the product has been removed or the equipment has been altered or modified. During the warranty period, the authorized service dealer, at its option, will repair or replace any part that, upon examination, is found to be defective under normal use and service.

NORMAL WEAR:

This warranty does not cover normal wear of parts or damage resulting from any of the following: negligent use or misuse of the product; improper voltage or current; use contrary to the operation instructions; deviation from instructions regarding storage and transportation; repair or alteration by anyone other than the manufacturer or an authorized service center. Further, the warranty does not cover Acts of God, such as fire, flood, hurricanes, and tornadoes. The manufacturer shall not be liable for any incidental or consequential damages caused by the breach of any express or implied warranty. This warranty gives you specific legal rights, and you may also have other rights that vary from state to state or province to province.

HOW TO OBTAIN WARRANTY SERVICE:

If your item should prove to be defective within the warranty period, we will repair it, or if we determine it is necessary, replace it. To obtain warranty service, simply email appliancesupport@monchateau.us or call our toll-free number 877-246-0990 for additional information from our Customer Service Representatives.

This warranty is effective for the time period listed above and subject to the conditions provided for within this policy.

REGISTER YOUR PRODUCT

To register, visit <https://mcappliances.us/product-registration> or scan the QR Code:



Sur la table

KITCHEN ESSENTIALS

**5 QT COMPACT
AIR FRYER**

Customer Service:

TEL: (877) 246-0990

www.surlatable.us

appliancesupport@monchateau.us

MODEL: SE-1703-5