

Sur la table

SINGLE OR DOUBLE BASKET
AIR FRYER

11 QUART/10.5 LITER

OWNER'S MANUAL



www.mcappliances.us

SLT-1805 MODEL

BEFORE USE, PLEASE READ AND FOLLOW ALL IMPORTANT SAFEGUARDS, WARNINGS, CAUTIONS AND OPERATING INSTRUCTIONS.



Congratulations! You now own a Single or Double Basket Air Fryer that allows you to simultaneously cook 2 different foods done 2 different ways at the touch of a few buttons. It comes with easy digital preset controls for Air Fry, Roast, Broil, Reheat, Dehydrate, Keep Warm, French Fries, Sync, Switch, and Dual Cook.

Create chef quality meals without the extra calories. It's the healthier choice of preparing your favorite crispy foods and delicious dishes for the entire family.

Please read the manual carefully before use and keep this manual for easy reference. **Enjoy!**

Sur la table

© 2022 Sur la table. All Rights Reserved.

Products mentioned herein are for identification purposes only and may be registered trademarks of their respective companies. All brand names, trademarks or registered trademarks are the property of their respective owners.

This manual is only applicable to SLT-1805. All the contents in this manual are for reference only during the user's use and maintenance. The pictures are for reference only. All the contents in the manual have been carefully checked. If there are any printing errors or misunderstandings in the contents, the company reserves the right to interpret.

TABLE OF CONTENTS

READ ALL INSTRUCTIONS PRIOR TO OPERATING	6
IMPORTANT SAFEGUARDS AND WARNINGS	6
WHAT'S IN THE BOX	12
SINGLE OR DOUBLE BASKET AIR FRYER FEATURES	16
SINGLE OR DOUBLE BASKET AIR FRYER ASSEMBLY	16
BEFORE THE FIRST USE	17
PRE-PROGRAMMED COOKING SELECTIONS	18
QUICK START GUIDE	19
AIR FRYING TECHNIQUES	22
COOKING HINTS	23
CLEANING AND MAINTENANCE	24
STORING INSTRUCTIONS	24
ENVIRONMENT FRIENDLY DISPOSAL	24
WARRANTY	24



READ ALL INSTRUCTIONS PRIOR TO OPERATING

- This manual is a comprehensive step-by-step user instruction guide for the **Single or Double Basket Air Fryer SLT 1805** and components.
- Make sure to read, understand and follow all these instructions.
- To address any questions relating to ordering parts, operating, assembly, troubleshooting, maintenance, service or anything else; contact **Customer Service Support Team at 1-877-246-0990 or email us at appliancesupport@monchateau.us**
- **Keep this manual in a location where it may be used for ongoing reference.**

IMPORTANT SAFEGUARDS AND WARNINGS

- Unplug the **Single or Double Basket Air Fryer** from outlet when **NOT in use**, before putting on or taking off parts, and before cleaning or removing contents from air fryer. Make sure air fryer has cooled down first for about 30 minutes. Before disconnecting plug, press ON/OFF control to turn off the air fryer, then remove power plug from power outlet by grasping the plug, not the cord.
- **WARNING: Always keep a fire extinguisher nearby when cooking.**
- **Never leave the air fryer unattended when in use.**
- **Never** put hands directly on the surrounding surfaces as they may be hot and can cause serious injuries or burns.
- **Always** use oven mittens to grab basket handles, crisper baking tray, separator, and remove food from air fryer since hot surfaces can cause serious injuries or burns. **Never** touch the hot food.
- Always grab the basket by its handles.
- Always allow air fryer or oven to cool before cleaning or handling, putting on or taking off parts.
- Always make sure the air fryer basket is fully inserted and locked in place before operating.
- The **Single or Double Basket Air Fryer** is a household appliance designed for indoor use **ONLY** and normal temperature conditions.
- Do **NOT** use the **Single or Double Basket Air Fryer** outdoors, it could cause serious injuries if it gets wet.

- Make sure the voltage of the power source is the same as specified on the rating plate of the **Single or Double Basket Air Fryer**. The use of an incorrect power source connection voids the warranty and can cause a fire, death, or serious injuries.
- Do **NOT** let power cord hang over the edge of counter, or touch hot surfaces.
- Do **NOT** operate the **Single or Double Basket Air Fryer** with a damaged cord or plug or after the appliance malfunctions or has been damaged in any manner. Return the appliance to the nearest authorized service facility for examination, repair, or adjustment.
- Close supervision is necessary when any appliance is used near children.
- The use of attachments not recommended or sold by manufacturer may cause fire, electric shock, death, or serious injuries.
- **Children cannot use the Single or Double Basket Air Fryer. Keep this appliance and its cord out of the reach of children and pets.**
- When removing food basket from the air fryer, make sure the appliance is off to avoid serious injuries or burns.
- **Make sure you always have a First-Aid Kit nearby.**
- **Always operate the Single or Double Basket Air Fryer with the basket secured in place.**
- **When using the crisper baking tray(s), make sure they are properly inserted into each air fryer basket before cooking. Place food on top of crisper baking tray(s).**
- **To check on food, use oven mittens to grab the basket handles and partially pull open the basket. If food is cooked, turn off the air fryer if not push basket back in place and continue cooking.**
- **WARNING: The Single or Double Basket Air Fryer will NOT function unless the basket is fully inserted and locked in place.**
- **WARNING: The basket, crisper baking tray(s) and separator will be extremely HOT after every use. Make sure you use oven mittens to protect your hands.**
- Do **NOT** use the **Single or Double Basket Air Fryer** for other than its intended use.
- Always unplug the **Single or Double Basket Air Fryer** from the power outlet if it is left unattended or not being used.
- To protect against electrical hazards, and permanent damage **NEVER** put the **Single or Double Basket Air Fryer** in water or other liquids.
- Avoid coming into contact with hot parts to avoid serious injuries.
- **When in use handle the Single or Double Basket Air Fryer with care to avoid serious burns and injuries.**
- Do **NOT** operate the **Single or Double Basket Air Fryer** in an appliance garage. When storing this air fryer in an appliance garage, always unplug the unit from electrical outlet. Not doing so could create a risk of fire, especially if the oven touches the walls of the garage or the door touches the unit as it closes.

IMPORTANT SAFEGUARDS AND WARNINGS (CONT.)

- **The Single or Double Basket Air Fryer will be hot after each use until it cools down — do not touch with bare hands since this could cause serious injuries and burns.**
- The **Single or Double Basket Air Fryer** should **NOT** be used in staff kitchen areas, shops, offices, other working environments, farm houses, in hotels or motels, bed and breakfast rentals, or any other types of residential environments.
- Do **NOT** place the **Single or Double Basket Air Fryer** next to or near a fryer, countertop oven or any other appliance that might get hot.
- Protect the **Single or Double Basket Air Fryer** from direct sunlight, prolonged water splashes and humidity.
- The **Single or Double Basket Air Fryer** should **NOT** be used by or near children or individuals with certain disabilities.
- The **Single or Double Basket Air Fryer** must **NOT** be used, cleaned, or maintained by children.
- The **Single or Double Basket Air Fryer** is **NOT** a toy and can **NOT** be use by children to play.
- The brand owners, manufacturer, partners, affiliates, or anyone working with the production of the **Single or Double Basket Air Fryer** accepts no responsibility and warranty will be voided; if the **Single or Double Basket Air Fryer** is commercially use, inappropriately handled or used; any damage from misuse, faulty operation, non-professional repairs or failure to comply with the instructions in this manual and the proper use of this appliance.
- **WARNING: Avoid risk of fatal electrical shock and fire. Electricity and water together are dangerous and can lead to fatal electrical shocks, death, or serious injuries.**
- In case of an emergency, immediately remove the power plug from the power outlet. **ONLY** plug the **Single or Double Basket Air Fryer** into suitable, easily accessible and grounded outlet connections.
- Keep the power cord away from heat, dampness, and moisture of any kind.
- If the power cord is damaged, **DO NOT USE** the **Single or Double Basket Air Fryer** until the power cord is replaced by the manufacturer, its service agent, or a similar qualified and certified technician in order to avoid all risks included but not limited to fire, death, and personal serious injuries.
- To avoid hazardous damage, never place the **Single or Double Basket Air Fryer** on or beside hot surfaces such as radiators, stoves, ovens, gas burners, open flames or any surfaces that are not sturdy.
- Do **NOT** touch any hot surfaces or steam to avoid serious injuries. Use handles and oven mittens.

- Always place the **Single or Double Basket Air Fryer** on a horizontal, stable, sturdy and even surface that is heat resistant and away from walls and other objects by at least 4 inches.
- Never place the **Single or Double Basket Air Fryer** underneath a cabinet or shelf or inside a cabinet. Air must always be allowed to circulate around the air fryer.
- Disconnect the power cord by pulling out the plug, do **NOT** pull on the cord itself to avoid damages.
- **Never** touch the cord with wet hands.
- **Never** put the **Single or Double Basket Air Fryer** or any part of it in the dishwasher except for the crisper tray or basket separator.
- **NEVER** put aluminum foil in the air fryer basket.
- **CAUTION HOT SURFACES: This Single or Double Basket Air Fryer generates heat and may release steam during use. Proper precautions must be taken to prevent the risk of burns, fires or other injuries to persons or damage to property.**
- **CAUTION: The Single or Double Basket Air Fryer retains heat for some time after turning OFF.**
- Do **NOT** open the factory set screws on the **Single or Double Basket Air Fryer** to look inside the motor because there is dangerous voltage inside, and this can cause fire, death, or serious injuries. Do **NOT** dismantle or open the air fryer in any way since this will void the warranty. Do **NOT** put anything into any openings; doing so may cause fire, electric shock, death, or serious injuries.
- The use of accessory attachments not recommended by the manufacturer will void warranty and may result in fire, electric shock, death, or serious injuries.

WARNING: Avoid possible harm when operating the Single or Double Basket Air Fryer.

- Do **NOT** use the **Single or Double Basket Air Fryer** if it is damaged, has been dropped or **NOT** operating properly. Immediately remove the power plug from the power outlet.
- Do **NOT** use any strong cleaning agents or solvent cleaners. Use a damp cloth and mild cleaning agents to clean the surface and removable parts for the **Single or Double Basket Air Fryer**. Make sure surfaces are dry.
- Do **NOT** use steam or a pressure cleaner to clean the **Single or Double Basket Air Fryer**, this may damage the appliance to the point of creating a life-threatening hazard, electrical shock, death, or serious injuries.
- To clean the **Single or Double Basket Air Fryer**, use only clean cleaning tools.
- When unpacking the **Single or Double Basket Air Fryer**, remove any plastic film and dispose of it.
- Do **NOT** let children play with the packing materials, plastic film, or box for the **Single or Double Basket Air Fryer**; since these can be a choking hazard, and cause death or serious injuries.

IMPORTANT SAFEGUARDS AND WARNINGS (CONT.)

- If you are sensitive to heat or are unable to feel hot surfaces, you **MUST** wear heat protective gloves to prevent serious injuries from hot surfaces.
- Do **NOT** clean the **Single or Double Basket Air Fryer** with cleansers, steel wool pads, or other abrasive materials.
- **WARNING: TO REDUCE THE RISK OF FIRE OR ELECTRIC SHOCK, DO NOT REMOVE THE BASE PANEL. NO USER-SERVICEABLE PARTS ARE INSIDE. REPAIRS SHOULD BE DONE ONLY BY AUTHORIZED PERSONNEL.**
- Do **NOT** place cloth beneath the **Single or Double Basket Air Fryer** or otherwise restrict airflow.
- To avoid burns, use extreme caution when removing Air Fryer Basket or accessories disposing of hot grease.
- Do **NOT** place any of the following materials in the Air Fryer: paper, cardboard, plastic, foil wrap and similar products. **ONLY** place foods inside the basket or on top of the crisper baking tray(s).
- **WARNING: The Single or Double Basket Air Fryer should not be used to boil water.**
- **WARNING: The Single or Double Basket Air Fryer should not be used to deep fry foods.**
- Oversize foods, metal foil packages and utensils must **NOT** be inserted in the **Single or Double Basket Air Fryer**, as they may cause a fire or electric shock.
- A fire may occur if the **Single or Double Basket Air Fryer** is covered or touching flammable materials such as curtains, draperies, or walls, when in operation. Do **NOT** store or place any items on top of the appliance when in operation.
- Do **NOT** clean with metal scouring pads. Pieces can break off the pad and touch electrical parts, involving a risk of electric shock or fire.
- Use recommended temperature settings for all cooking, baking, roasting and air frying.
- **WARNING: Under or over filling the air fryer basket may damage the air fryer and result in serious personal injuries.**
- Do **NOT** move the **HOT Single or Double Basket Air Fryer** while in use or while it contains hot food.
- **Never place a cooking container full of grease or hot liquids inside the Single or Double Basket Air Fryer .**
- **Clean air fryer basket, crisper baking tray(s) and separator after each use.**

Electrical Power

- If the electrical circuit is overloaded with other appliances, your **Single or Double Basket Air Fryer** may not operate properly. It should be operated on a separate electrical circuit from other appliances.

WARNING: RISK OF FIRE OR ELECTRIC SHOCK

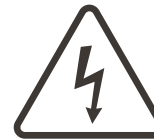

**WARNING: TO REDUCE THE RISK OF FIRE OR ELECTRIC SHOCK,
DO NOT REMOVE COVER (OR BACK)
NO USER-SERVICEABLE PARTS INSIDE
REPAIR SHOULD BE DONE BY AUTHORIZED SERVICE PERSONNEL ONLY**

Short Cord Instructions

- To reduce the risk of electric shock, this power cord is intended to fit into a polarized outlet **ONLY** one way. If the power cord plug does **NOT** fit fully into the power outlet, reverse the power cord plug and insert into the power outlet. If it still does not fit, contact a qualified electrician or customer service.
- Do **NOT** attempt to modify the power cord plug in any way.

**SAVE THESE INSTRUCTIONS
HOUSEHOLD USE ONLY**

WHAT'S IN THE BOX

7ⁱⁿ1
 MULTI-FUNCTIONAL
 AIR FRYER

3
 ACCESSORIES

Air Fry, Roast, Broil
 Bake, Reheat, Dehydrate,
 Keep Warm

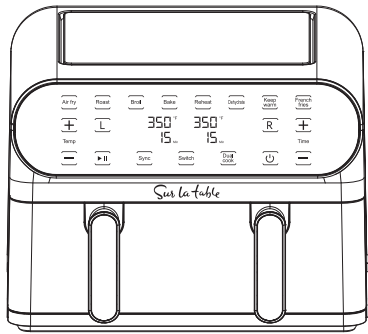

A
AIR FRYER

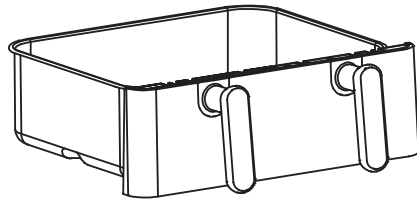

B
AIR FRYER BASKET

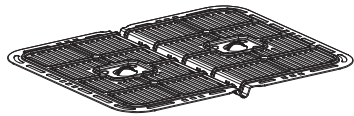

C
**CRISPER BAKING-
 TRAY**

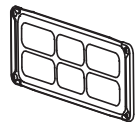

D
SEPARATOR

ONLY THE CRISPER BAKING TRAY AND THE SEPARATOR ARE DISHWASHER SAFE



GETTING TO KNOW YOUR 11-QT MULTIFUNCTIONAL AIR FRYER

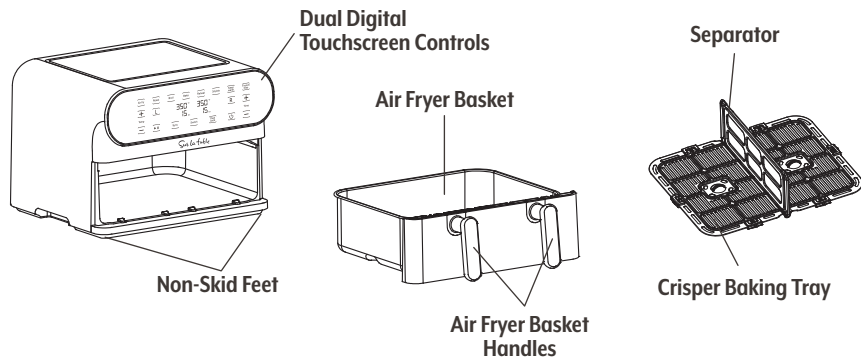

Product may vary slightly from illustration.

CONTROL PANEL

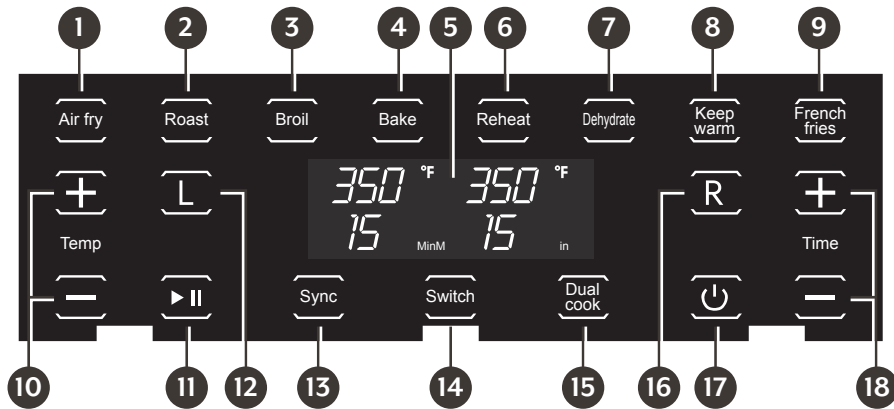

1 AIR FRY

2 ROAST

3 BROIL

4 BAKE

5 DUAL DIGITAL TEMP & TIME DISPLAY

6 REHEAT

7 DEHYDRATE

8 KEEP WARM

9 FRENCH FRIES

10 TEMP CONTROL (+ OR -)

- Press + or - on the left side of the control panel to increase or reduce TEMP in 5 degree increments.

11 START OR PAUSE

- Once programming is complete, press the START and PAUSE to start the cooking process or PAUSE any operation.

12 LEFT BASKET CONTROL

- **NOTE:** LEFT or RIGHT Baskets may be programmed independently at any time before or during operation.
- The L or R Control will illuminate steadily on the screen when active. To adjust or add programming at any time, press the appropriate L or R Basket Control. When the Control begins to flash, TEMP and TIME can be adjusted.

13 SYNC FOOD FINISH

- Both LEFT and RIGHT Baskets must first be programmed.
- Press SYNC to ensure both baskets will finish cooking together. Then press START and PAUSE Control to begin operation.
- Cooking time will appear on the L and R sides and the countdown will begin on the side with more time. When the remaining time on L and R sides is even, the countdown will proceed on both sides.
- **NOTE:** Once cooking has started, SYNC function will not be operable.

14 SWITCH

- Press SWITCH Control to enter Single Basket without Separator. The L/R, SYNC and DUAL COOK Controls won't light up. Only one set of TIME and TEMPERATURE will be displayed.

15 DUAL COOK

- Press DUAL COOK to effortlessly duplicate settings for both LEFT and RIGHT Air Fryer Baskets. After pressing DUAL COOK, you can simply adjust the temperature and time for both Baskets at the same time.

16 RIGHT BASKET CONTROL

17 ON/OFF CONTROL

- When the Air Fryer is plugged in, a tone will sound, the ON/OFF Control will light up, indicating that the unit is powered on.
- When ON/OFF is pressed, a tone will sound and all the Controls will light up.
- When in operation, press ON/OFF Control to turn both LEFT and RIGHT Basket Controls OFF.

18 TIME CONTROL (+ OR -)

- Press + or - on the right side of the control panel to increase or decrease TIME in 1 minute increments.
- **NOTE:** When using the DEHYDRATE, TIME will increase or decrease in 1 hour increments.

FEATURES

- Dual Digital Touchscreen Controls
- Digital Temperature and Time Display
- Removable Air Fryer Basket with Handles
 - 11 Quart or 2 x 5.5 Quart Each
- Removable Crisper Baking Tray
- Removable Separator
- Non-Skid Feet
- Preset Menu Controls
 - Air Fry, Roast, Broil, Bake, Reheat, Dehydrate, Keep Warm, French Fries
 - Sync, Switch, Dual Cook
- Temperature Controls
- Time Controls
- Left and Right Basket Controls
- ON/OFF Control
- Start and Pause Control

ASSEMBLY

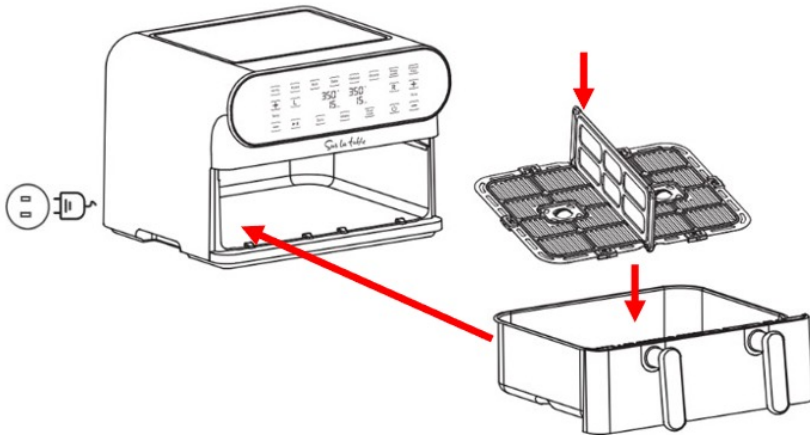

BEFORE FIRST USE

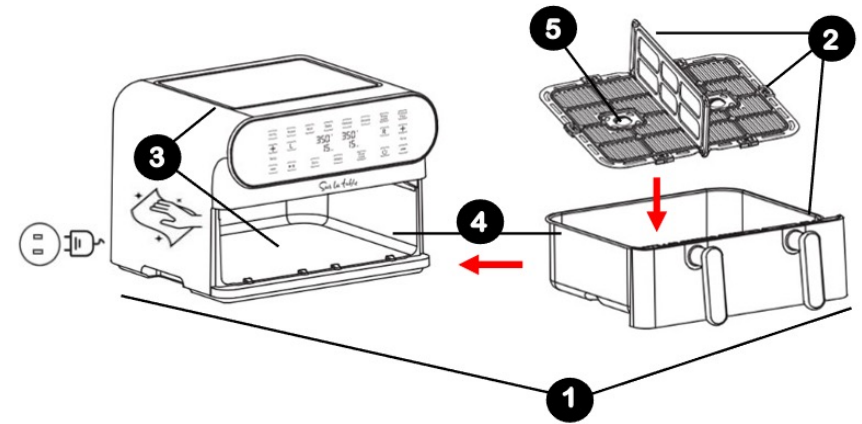

- 1 Check that all accessories are included, and the Air Fryer is in perfect condition. Remove all packaging materials.
- 2 Clean all detachable parts thoroughly with mild soap and water.
 - Removable Air Fryer Basket, Crisper Baking Tray, and Separator
- 3 Use a damp cloth to wipe the inside and outside of the Air Fryer and a dry cloth to dry it. DO NOT immerse Air Fryer Body in water.
- 4 After cleaning, dry and place all detachable parts in the Air Fryer.

NOTE: During first use, the Dual Air Fryer may emit a slight odor. This is normal and will not affect the flavor of the food.

PRE-PROGRAMMED COOKING SELECTIONS

MENU	DEFAULT TEMP (°F)	DEFAULT TIME	DUAL COOK TIME	TEMP RANGE (°F)	TIME RANGE
Air Fryer	400	20 mins	23 mins	170 - 400	1 - 60 mins
Roast	400	35 mins	37 mins	350 - 400	1 - 60 mins
Broil	400	10 mins	13 mins	400	1 - 30 mins
Bake	350	16 mins	19 mins	170 - 400	1 - 60 mins
Reheat	250	6 mins	9 mins	170 - 400	1 - 60 mins
Dehydrate	130	8 hours	8 hours	90 - 170	1 hr - 24 hrs
Keep Warm	170	60 mins	60 mins	150 - 200	1 - 60 mins
French Fries	400	20 mins	30 mins	170 - 400	1 - 60 mins

QUICK START GUIDE

ASSEMBLE YOUR AIR FRYER

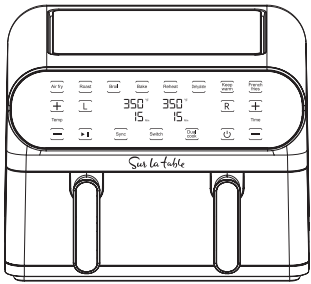

1. Place the air fryer on a flat, stable, heat resistant surface close to an electrical outlet.
Warning: Do NOT place the air fryer underneath cabinets.

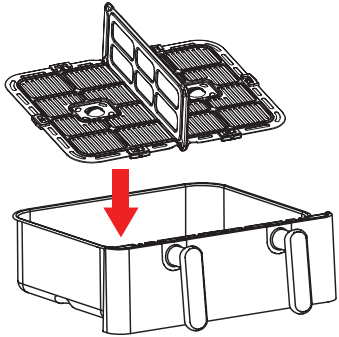

2. Insert the crisper baking tray with or without the separator.

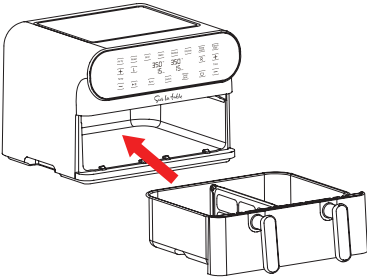

3. Insert the basket into the air fryer and lock into place.

START COOKING

IMPORTANT: Maximum food capacity for air fryer basket is 11 quarts of food per basket.

Cook using the full basket:

1. Plug the air fryer cord into an electrical outlet. The ON/OFF control will light up in white.
2. Place food on the crisper baking tray in the air fry basket without the separator.
 - a. **WARNING:** Do NOT Overfill. To ensure proper cooking and air circulation, NEVER fill any Air Fryer Basket more than 2/3 full.
 - b. **NOTE:** When air frying fresh vegetables, it is not recommended to add more than 2 to 3 cups of food to the Air Fryer Basket.
3. Insert the basket into the air fryer and lock into place.
4. Press the ON/OFF control. The control panel will illuminate.
5. Press Switch.
 - a. **NOTE:** The L, R, Sync, and Dual Cook buttons will turn off. Sync buttons will turn off.
6. Press the desired cooking function. The default cooking time and temperature with flash.
7. If necessary, adjust the cooking time and temperature using the + or – buttons.
 - a. **NOTE:** In the Dehydrate Setting, time is adjustable in 1 hour increments.
8. Press the start/pause button to initiate the cooking process.
 - a. **NOTE:** To pause the cooking process, press the start/pause button. To resume the cooking process, press the start/pause button.
 - b. **NOTE:** Two-thirds through the cooking process, the air fryer will beep and the display will show SHK, reminding you it's time to shake or flip your food for even cooking.
9. When the remaining time reaches 00:00, the display will show a countdown of 20 seconds, the air fryer will beep 5 times and turn off.

Cook using both baskets:

1. Plug the air fryer cord into an electrical outlet. The ON/OFF control will light up in white.
2. Place food on the crisper baking tray in the air fry basket with the separator.
 - a. **WARNING:** Do NOT Overfill. To ensure proper cooking and air circulation, NEVER fill any Air Fryer Basket more than 2/3 full.
 - b. **NOTE:** When air frying fresh vegetables, it is not recommended to add more than 2 to 3 cups of food to the Air Fryer Basket.
3. Insert the basket into the air fryer and lock into place.
4. Press the ON/OFF control. The control panel will illuminate.
5. Press the L button to set up the cooking process for the food on the left basket.
6. Press the desired cooking function. The default cooking time and temperature with flash.
7. If necessary, adjust the cooking time and temperature using the + or – buttons.
8. Press the R button to set up the cooking process for the food on the right basket.
9. Press the desired cooking function. The default cooking time and temperature with flash.

10. If necessary, adjust the cooking time and temperature using the + or – buttons.
 - a. **NOTE:** Press the Sync button to synchronize the cooking time in each basket so both dishes finish cooking at the same time.
11. Press the start/pause button to initiate the cooking process.
 - a. **NOTE:** To pause the cooking process, press the start/pause button. To resume the cooking process, press the start pause button.
 - b. **NOTE:** Two-thirds through the cooking process, the air fryer will beep, and the display will show SHK, reminding you it's time to shake or flip your food for even cooking.
12. When the remaining Time reaches 00:00, the display will show a countdown of 20 seconds, the air fryer will beep 5 times and turn off.

Cook using only one basket:

1. Plug the air fryer cord into an electrical outlet. The ON/OFF control will light up in white.
2. Place food on the crisper baking tray in the air fry basket with the separator.
 - a. **WARNING:** Do NOT Overfill. To ensure proper cooking and air circulation, NEVER fill any Air Fryer Basket more than 2/3 full.
 - b. **NOTE:** When air frying fresh vegetables, it is not recommended to add more than 2 to 3 cups of food to the Air Fryer Basket.
3. Insert the basket into the air fryer and lock into place.
4. Press the ON/OFF control. The control panel will illuminate.
5. Press the L or R button to set up the cooking process for the food in the desired basket.
6. Press the desired cooking function. The default cooking time and temperature with flash.
7. If necessary, adjust the cooking time and temperature using the + or – buttons.
8. Press the start/pause button to initiate the cooking process.
 - a. **NOTE:** To pause the cooking process, press the start/pause button. To resume the cooking process, press the start pause button.
 - b. **NOTE:** Two-thirds through the cooking process, the air fryer will beep, and the display will show SHK, reminding you it's time to shake or flip your food for even cooking.
9. When the remaining Time reaches 00:00, the display will show a countdown of 20 seconds, the air fryer will beep 5 times and turn off.

SPECIAL FUNCTIONS

Sync Food Finish:

Sync Finish feature independently adjusts temperature and cooking time in each basket to allow two different dishes to finish cooking at the same time. To set up, simply program both sides, press sync and start/pause.

The cooking time will appear on both sides and the countdown will begin on the side with more time. When the remaining time on both sides are even, the countdown will proceed on both sides.

NOTE: Once cooking has started, Sync function will not be operable.

Dual Cook:

Dual Cook function allows you to transfer settings from one basket to the other at the touch of a button. To set up, simply program one of the baskets with the desired cooking function, time and temperature. Then, press dual cook to copy that recipe on to the other basket. Finally, press the start/pause button to initiate the cooking process.

Shake:

Shake reminder lets you know when it's time to shake your food. You don't have to do anything to set this function up. Two-thirds through the cooking function, the display will show SHK reminding you to shake or flip your food for even cooking.

AIR FRYING TECHNIQUES

NOTE: Consult the Pre-Programmed Cooking Selections or follow the food package directions for suggested TIME and TEMPERATURE.

- Always pat food dry before cooking to promote browning and avoid excess smoke.
- Some recipes may call to brush or spray oil halfway through the cooking process and adjust TIME and TEMPERATURE.
- **WARNING:** Extreme caution must be used when handling any hot food, Basket, or Crisper Baking Tray(s). Avoid escaping steam from the Air Fryer Basket and the food.
- **CAUTION:** Always use oven mittens when handling the HOT Air Fryer Basket.
- **CAUTION:** Hot oil can collect at the base of the Basket. Use caution when removing cooked foods.
- To ensure crispiness, make sure the skin or exterior food surface is dry. Air Fry small batches of freshly breaded foods.
- Create more surface area by cutting food into smaller pieces.
- Press breading onto food to help it adhere.
- Refrigerate breaded foods for at least 30 minutes before Air Frying.
- Arrange breaded food in Air Fryer Basket so that the food is not touching to allow air to flow through all surfaces. Spray oil work best oil if distributed evenly; canola, olive, avocado, coconut, grapeseed, peanut, or vegetable oil work best.

COOKING HINTS

Air Frying Pre-Packed Frozen Foods

- As a rule, depending on the food and amount to be cooked, suggested cooking times may have to be reduced slightly.

Roast

- Use a meat thermometer inserted into the center of the meat to determine desired doneness.
- Cook meats to 5 to 10 degrees below desired doneness (internal temperature). Allow meat to stand 15 to 20 minutes before serving. The food temperature will continue to rise while the food is resting.
- Roast large, tender cuts of meat and poultry. Seasoning prior to cooking adds to the flavor and aroma during cooking.
- A layer of fat on the top of the roast promotes better browning and provides natural basting.
- To speed up the browning process, brush lean cuts of meat, chicken and fish with oil, margarine, or melted butter.

Broil

- Use BROIL to melt cheese or to brown crumb toppings.
- Typically, BROIL is used for thinner cuts of meats, or marinated meats, chops, poultry or fish, fruits, and vegetables.
- Dry marinated meats and fish before broiling. Always pat meat dry to reduce smoke and promote browning during broiling.
- To speed up browning and add flavor, brush lean cuts of meat, chicken and fish with oil or melted butter.
- Trim excess fat from meat and score edges to prevent curling.
- Thaw frozen meats and fish before broiling.
- Broil time is determined by the desired doneness. Always use a meat thermometer.

Bake

- Check package directions to determine if the container is suitable for use in an Air Fryer.

Dehydrate

- **NOTE:** When manually programming DEHYDRATE menu selection, TIME will increase or decrease in 1 hour increments.
- Dehydrate fresh, ripe foods to preserve nutrients and enhance flavor.

CLEANING AND MAINTENANCE

- This Air Fryer requires very little maintenance. It contains no user-serviceable parts. Any servicing requiring disassembly other than cleaning must be performed by a qualified appliance repair technician.
- **WARNING:** Allow the Single or Double Basket Air Fryer to cool fully before cleaning.
- Unplug the Single or Double Basket Air Fryer .
- Remove the Basket from the Air Fryer.
- Make sure Air Fryer Basket, Separator and Crisper Baking Tray have cooled completely before cleaning.
- Wash Air Fryer Basket, Separator and Crisper Baking Tray in warm soapy water and rinse well. Hand dry with a soft cloth.
- Do not use metal Kitchen utensils or abrasive cleaners or cleaning products as these may damage the non-stick coating.
- Only the crisper tray and basket separator are dishwasher safe. For best results place on the top rack.
- Wipe the Air Fryer with a soft, non-abrasive damp cloth to clean it. Then use a dry soft cloth to dry all surfaces.

STORING INSTRUCTIONS

- Make sure the Air Fryer is unplugged and all parts are clean and dry before storing.
- **Never store the Air Fryer while it is hot or wet.**
- Insert the clean Crisper Baking Tray and Separator inside the Air Fryer.
- Store Air Fryer in its box or in a clean, dry place.



Environment Friendly Disposal

You can help protect the environment! Please remember to respect the local regulations. Take non-working electrical equipment to an appropriate waste disposal center.

1 YEAR LIMITED WARRANTY

Customer Service:

(877) 246-0990

ApplianceSupport@monchateau.us

